

GAGGIA®



ISTRUZIONI PER L'USO
OPERATING INSTRUCTIONS
GEBRAUCHSANWEISUNG
MODE D'EMPLOI
INSTRUCCIONES DE USO
GEBRUIKSAANWIJZING
INSTRUCÇÕES E MODO DE
EMPREGO

mod. **CLASSIC**

CE

FIG.01

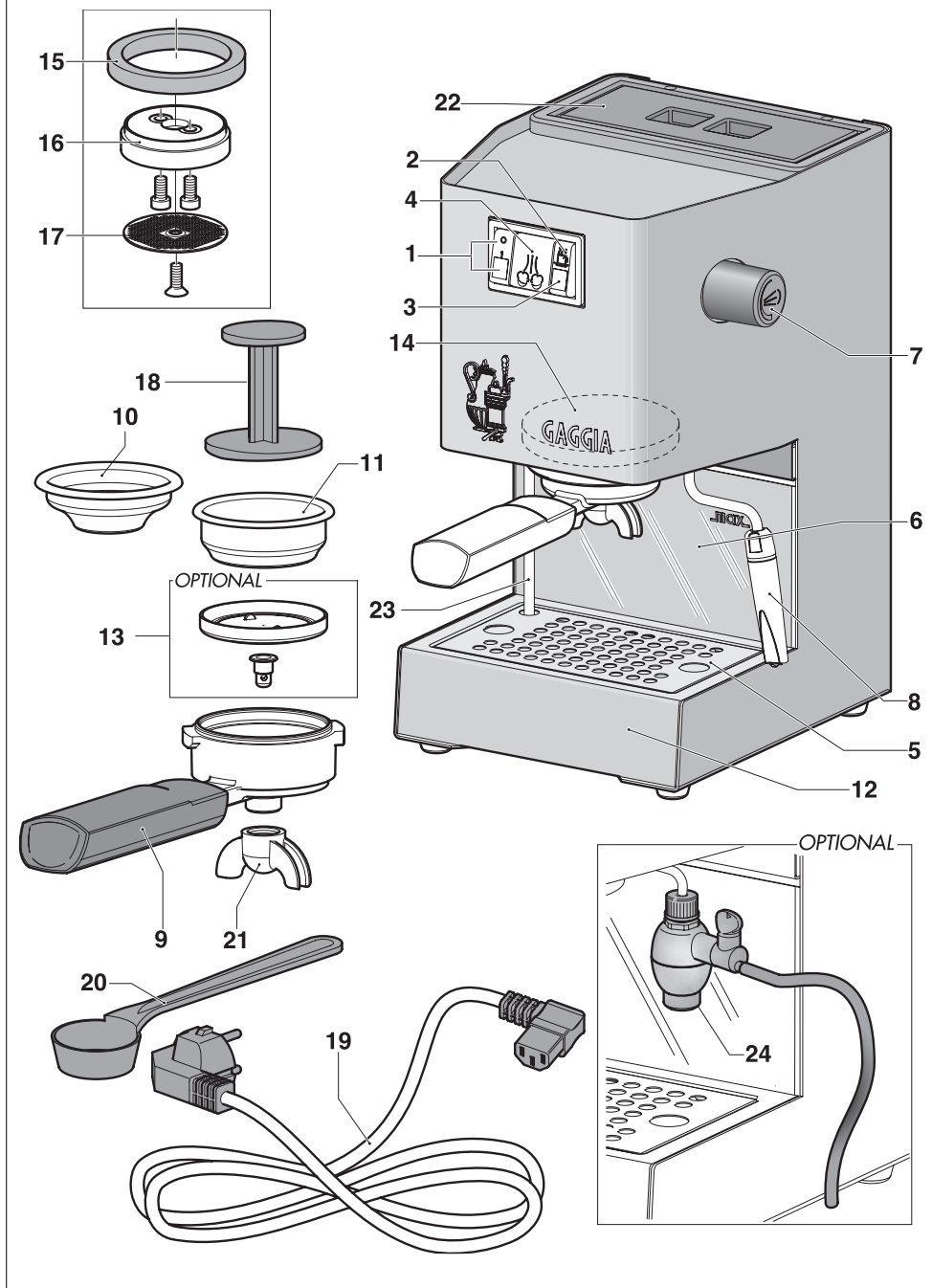

The first time you use the frother, you must...

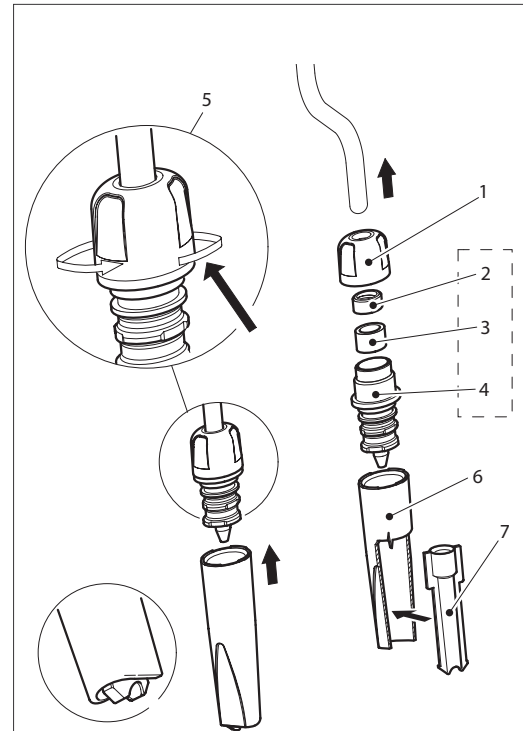

GB

- Slide the Ring Nut **1** onto the steam hose.
- Place the Gasket **3** into the Injector **4**, and place the Gasket Press **2** over the Gasket **3**. Slide the assembly **2-3-4** over the steam hose.
- Screw the Ring Nut **1** onto the Injector **4**. Tighten **5**.
- Attach the external housing **6** as shown in the Figure.
- The internal sleeve **7** must be correctly installed, by protruding the lower part of the external sleeve, as shown in figure.

FIG.02

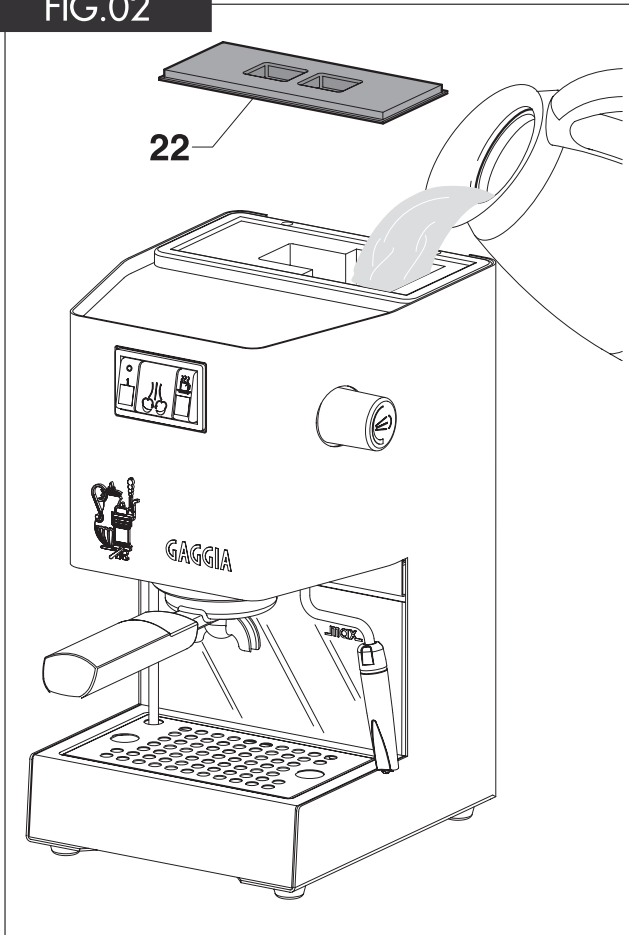

FIG.04

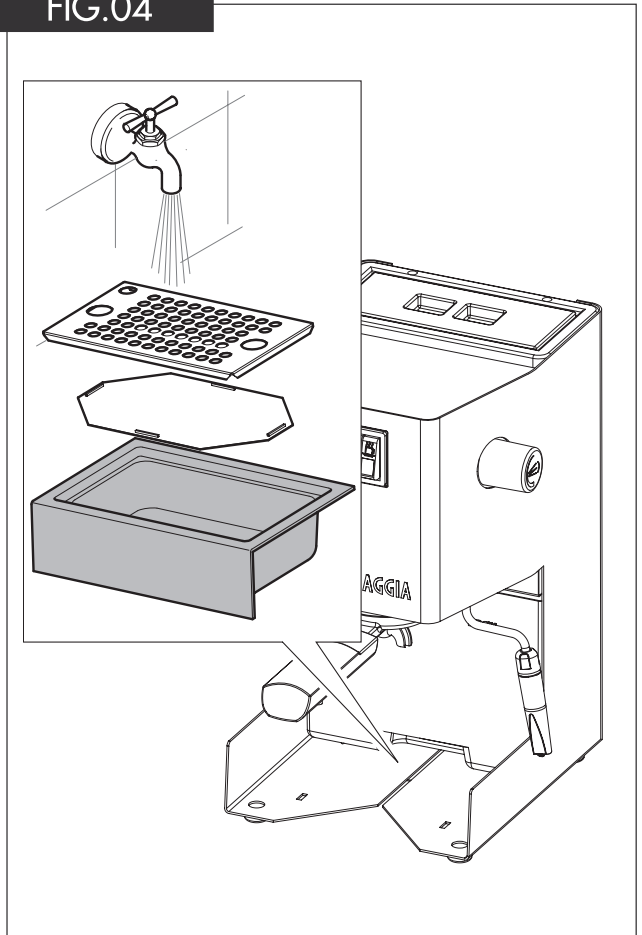
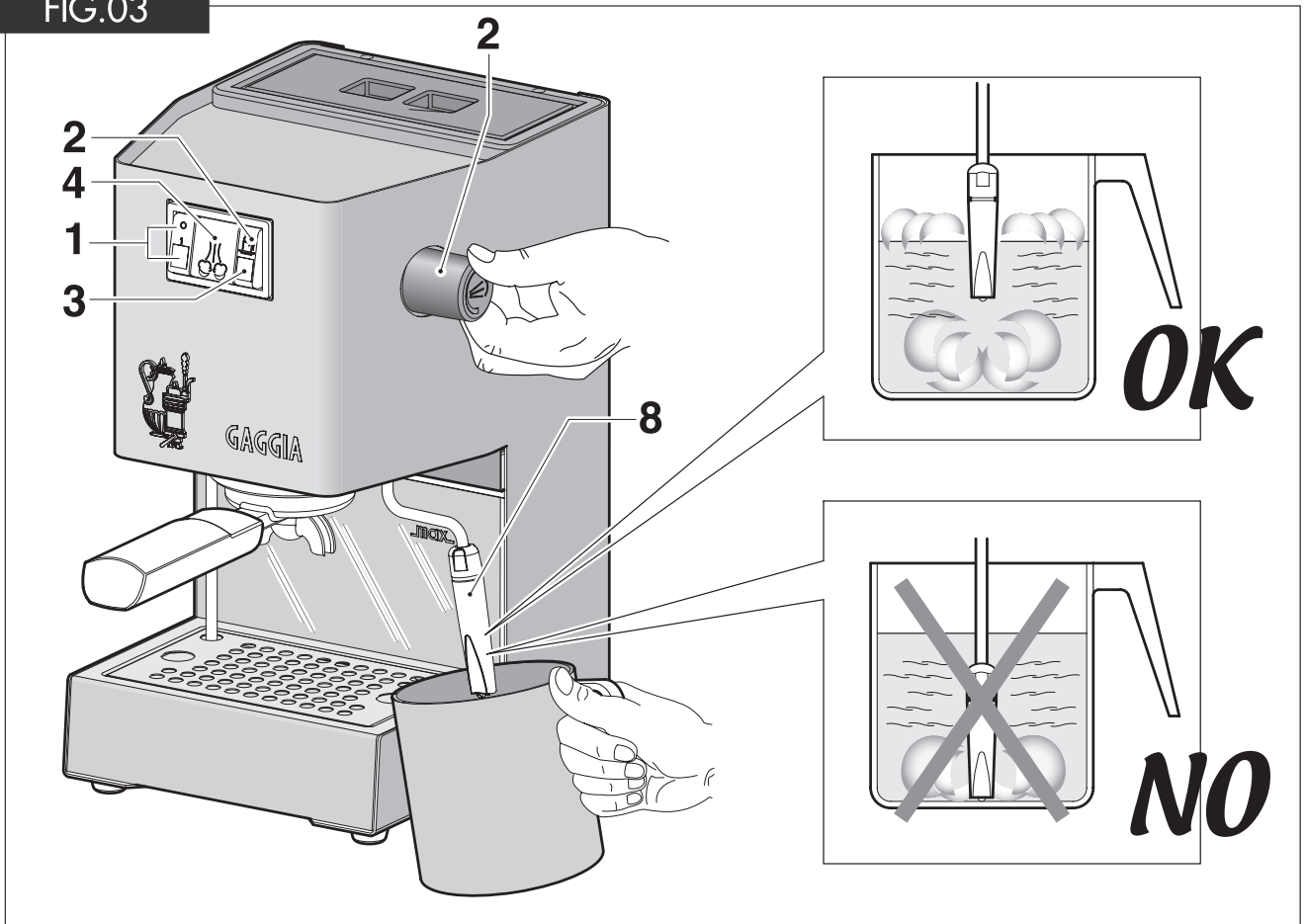

FIG.03



Congratulations on your wise choice!

As the proud owner of the Gaggia machine, you can now experience the taste of a delicious cup of espresso or cappuccino in the comfort of your own home.

Espresso coffee, originally created in Italy, is made by rapidly forcing water that has been heated to the correct brewing temperature, through a special finely ground coffee.

The heart of the espresso machine is a precision engineered pump.

The pump and water flow is easily controlled with just a flick of the switch.

**CAUTION:**

This appliance is for household use

Any repairs or servicing operations, with the exception of normal cleaning and maintenance operations must be undertaken by an authorized service centre.

1. Check voltage to be sure that the voltage indicated on the plate agrees with your voltage.
2. Never use warm or hot water to fill the water tank. Use cold water only.
3. Keep your hands and the cord away from hot parts of the appliance during operation.
4. Never clean with scouring powders or hard implements.
5. To avoid your machine scaling up, use purified or bottled water.
6. Do not immerse base in water.

IMPORTANT SAFEGUARDS

When using electrical appliances, basic safety precautions should always be followed to reduce the risk of fire, electric shock, and/or injury to persons, including the following:

- 1 Read all instructions and information in this instruction book and any other literature included in this packaging referring to this product before operating or using this appliance.
- 2 Do not touch hot surfaces. Use handles or knobs.
- 3 To protect against fire, electric shock and personal injury do not immerse cord, plugs, or appliance in water or other liquid.
- 4 Close supervision is necessary when any appliance is used by or near children.
- 5 Unplug from outlet when not in use and before cleaning. Allow to cool before putting on or taking off parts and before cleaning the appliance.
- 6 Do not operate any appliance with a damaged cord or plug or in the event of appliance faults or damages. Return appliance to the nearest authorized service centre for examination, repair or adjustment.
- 7 The use of accessory attachments not recommended by the appliance manufacturer may result in fire, electric shock or personal injury.
- 8 Do not use outdoors.
- 9 Do not let cord hang over edge of table or counter, or touch hot surfaces.
- 10 Do not place on or near a hot gas or electric burner, or in a heated oven.
- 11 Always turn appliance to "0", then plug cord into the wall outlet. To disconnect, turn switch to "0", then remove plug from wall outlet.
- 12 Do not use appliance for other than intended household use.
- 13 Use extreme caution when using hot steam.

SAVE THESE INSTRUCTIONS

Description of parts:

FIG. 01

- 1** On-Off-switch/Power-on light
- 2** Hot water/brew switch (pump)
- 3** Temperature ready-light
- 4** Steam switch (temperature)
- 5** Drip plate
- 6** Removable water tank
- 7** Steam/hot water knob
- 8** Turbo frother steam nozzle (removeable)
- 9** Filterholder
- 10** 1 cup filter (or coffee pod)
- 11** 2 cup filter
- 12** Drip tray
- 13** "Perfect crema" device
- 14** Brewing head
- 15** Filterholder gasket
- 16** Shower disc holder
- 17** Shower disc
- 18** Tamper
- 19** Power cable and plug
- 20** Measuring spoon
- 21** Delivery spout
- 22** Tank cover
- 23** Removable decompression duct
- 24** Milk frother (removeable)

Instructions for the power supply cord

- A** A short power-supply cord is provided to reduce risks of getting tangled up or tripping over a longer cord.
- B** Longer extension cords are available and may be used if care is exercised in their use.
- C** If a long extension cord is used:
 - 1 the marked electrical rating of the extension cord should be at least as great as the electrical rating of the appliance.
 - 2 if the appliance is of the grounded type, the extension cord should be a grounding type
 - 3 the cable does not hang from the table to avoid the risk of getting caught up in it.

Preparation:

1. Remove the water tank cover (22) and fill with cold water to the MAX line indicated on tank (6). See FIG. 2.

The water tank can also be removed after disconnecting the decompression duct (23) by pulling it down and removing the drip plate (5) and the drip tray (12).

IMPORTANT: *Once the tank has been reinserted, ensure that the silicon pipes are inside the actual tank and not tangled or blocked.*

The decompression duct is again in the original place by pushing it up.

2. Insert plug (19) into a suitable wall outlet (see point 1 under "Caution").
3. Turn the power switch (1) to "1". The power-on indicator light will light up.
Make certain that the hot water/coffee switch (2) and that the steam switch (4) are in the "0" position.

Starting up

This procedure fills the water boiler with fresh water.

This should be done whenever the machine is switched on.

This machine, featuring a pump to brew coffee, is equipped with a self-priming system. Place an empty cup under the brewing head (14), do not insert filter holder and press hot water/coffee switch (2) (pos. "1").

You will hear the sound of the operating pump and after few seconds, water will start to escape from the brewing head (14).

Once cup is filled, set coffee switch (2) onto pos "0".

The Gaggia machine is now ready to be used.

NOTE: It may happen that the self-priming feature of the pump fails to work temporarily due to an air lock.

In this case water does not flow from brewing head (14), and the following procedure should be followed:

- a) Place a small frothing pitcher or mug under the steam nozzle (8).
- b) Turn the steam knob (7) counter-clockwise to open the steam/hot water valve, and turn the steam switch (4) and the hot water/brew (2) to "1" to activate the pump.
- c) After a few seconds, a steady stream of water will emerge from the steam nozzle. Allow about one cup of water to fill the pitcher. Shut the steam/hot water valve and turn hot water/brew switch and the steam switch (4) to "0".

The Gaggia machine is now ready to be used.

- d) **NOTE:** *The temperature ready-light (3) will automatically flash as the machine boiler heats.*

After switching on the machine for the first coffee, wait 6 minutes until the machine has fully heated up, while for all subsequent coffees the machine will be ready to use.

Another feature of the machine is the "no-drip system", eliminating most of dripping from brewing head (14). After coffee brewing, however, a little dripping may occur due to wet coffee grinds in the filter-holder.



Caution: Never operate pump without water in machine as damage to the pump may occur. Damage of pump run without water is not covered by warranty.

Important to know.....

1. The taste of your coffee depends on the characteristics of the beans from which it is made, the type of bean, where it was grown and processed. The coffee beans that are roasted for a longer period of time and at higher temperatures will be much darker in colour. Darker beans will produce a richer cup of coffee than the lightly-roasted beans.
2. A variety of dark roasts are available from which you can choose to brew your espresso. Each of these roasts is a blend of coffee beans that are roasted at a specific temperature producing a specific type of flavour. There are decaffeinated beans that have up to 98% of the caffeine content removed. The next time you purchase coffee for your espresso maker, experiment with one of the many kinds of coffee being sold. You may just find that it tastes better than the blend you have been using.
3. A fine "espresso grind" for pump-driven machines must be used. Be sure to ask for this when buying coffee or when having beans ground. Do not use a blade-type grinder because it makes too much coffee dust and produces an irregular grind.
4. The mark of real espresso is its dark color, rich taste and the light brown, natural froth called "crema" in Italian.
5. Cappuccino is simply a combination of espresso and hot, frothy milk. Cappuccino is usually topped with cinnamon, nutmeg or cocoa powder.
6. Espresso Coffee should be served immediately after it is made.
7. Espresso is served in 2 to 2 ½ oz. demitasse cups. A 4 or 6 oz. cup or glass is used for cappuccino
8. Ideally, coffee beans should be ground immediately before using. Remember, it must be an "espresso grind" for pump-driven espresso machines.
9. It's best to store ground coffee or beans in an airtight container in the freezer of your refrigerator. Ground coffee tends to absorb food odours.

How to make a good Espresso coffee:

- 1 Follow the procedure described under "Preparation".
- 2 Select the correct filter basket (10 or 11) and insert it in the filter holder (9).
Use the small filter for 1 cup and the large filter for 2 cups of espresso.
Then insert the filter holder (9) into the brewing head (11) to warm-up
- 3 Wait until the machine has reached the correct temperature with filter holder inserted (heating time of about 6 minutes).
Use this time to set table, prepare cups, coffee, milk, etc
- 4 After the warm-up period, remove the warm filter-holder (9) from the brewing head and fill with correctly ground espresso coffee using the measuring spoon provided.
Place one level measure of coffee in basket for each cup of espresso. Do not overfill.
Gently tamp down coffee with the tamper (18) provided. Do not compress too firmly.
- 5 Clean any excess coffee from the rim of filter holder (9). Insert filter holder into brew head by holding handle approximately 45 degrees to the left as you face machine. When properly aligned, move handle firmly to the right to lock into position.
The handle should point to the front of the machine or slightly to the right.
- 6 Place one or two espresso cups on the drip plate to line up with the spouts of the filter holder. Depress hot water/brew switch (2) to pos. "1". Espresso will start to flow into cups.
- 7 When cups are 3/4 full, release brew switch to "0". The more water you allow to flow, the weaker the coffee. When properly made, the espresso will have a light brown foam "crema" floating on the top.
If not, refer to "**In the event of faulty function**".
- 8 Remove cups and serve.
- 9 To make more espresso, carefully and slowly remove the filter holder by moving handle to the left. Be careful as hot water will be on top of the coffee grinds in the holder. Some water will continue to drip from brewing head as filter holder is removed. That is normal and due to the pump pressure in the system.
Knock out used coffee grinds from filter. For more espresso repeat steps 4 to 8 above

OPTIONAL

"Perfect crema" device (13)

To ensure the optimum function of the "Perfect cream" device, insert the frothing jet device into the filter holder.

We recommend that the "Perfect cream" device be cleaned on a daily basis, before use, in order to prevent any blockage of the delivery holes. A pin may be used to clean out the hole.

Even if the type of coffee grinding is not correct the use of the "Perfect cream" device will produce the typical creamy froth of an espresso coffee.

N.B.: Only use the "perfect cream device with a large 2-cup filter.

Preparing cappuccino:

When preparing to make a cappuccino, have all of the ingredients at hand as well as a frothing pitcher (or mug) half-filled with skimmed or low-fat milk and cups that are larger (6 oz.) than those used for espresso.

Frothing Milk:

The higher the fat content in the milk the denser the froth will be. The Turbo-Frother (8) or milk frother (24) will give you all the froth required but don't let milk come to a boil.

It may require two or three attempts to "become an expert" but you will be successful at frothing milk if you give it a chance. Swivel the Turbo-Frother steam nozzle (or milk frother) slightly outward so that you can get the frothing pitcher under the nozzle without knocking the base of the machine.

Turbo frother steam nozzle version:

- 1 Make espresso (in a large cups) as described above
- 2 Position steam switch (4) to "1".
- 3 After 15 to 20 seconds or, when temperature ready-light (3) goes on, place the frothing pitcher half-filled with low-fat milk under Turbo Frother steam nozzle so that tip is just under the surface of the milk. See Fig.03.

- 4 Slowly turn steam valve knob (7) counter clockwise to release steam.

IMPORTANT. *The more you turn the knob, the greater the steam pressure for frothing.*

N.B.: *Dispensing should not exceed 60 seconds.*

- 5 Move pitcher in circular motion keeping the tip of steam nozzle just under surface of milk as it begins to froth. Do not let milk come to a boil since it will not froth.
- 6 When you have made enough froth, turn steam knob clockwise to shut off steam and remove pitcher. Put steam switch (4) to pos. "0".
- 7 Spoon the froth onto the espresso in each cup and gently pour the hot milk along the side of the cup. Top each cup of cappuccino with a dash of cinnamon, cocoa and nutmeg. Serve.
- 8 **NOTE:** *If you want to make more espresso immediately after steaming milk, the machine boiler must be refilled with water and temperature brought down to a brewing temperature. Otherwise, espresso may taste "burned". To do this: place an empty cup on drip plate. Do not insert filter holder. Turn hot water/brew switch (4) to "1" letting cup fill with water. Turn brew switch "0". You may now proceed to make more espresso.*

OPTIONAL

Milk frother (24)

The milk frother (24) is a special device that allows an easy frothing by sucking milk directly out from its container.

When preparing to make cappuccino, have all the ingredients at hand as well as a container of cold milk and cups that are larger than those used for espresso.

Make sure that the milk frother (24) is correctly mounted on the steam nozzle (A) by turning the ring nut (B), and place the suction pipe (C) into the cold milk container.

It is possible to adjust the amount of milk that is sucked up by means of the bar (D). The position that is shown in the picture indicates the maximum suction, milk is lukewarm. By turning the bar (D) 180°, the minimum suction is set, and milk is warmer.

Milk frother version:

- 1 Make espresso (in large cups) as described above.
- 2 Depress steam switch (4) to "1".
- 3 After 10 to 15 seconds or when the temperature ready-light (3) goes on, place the suction pipe (C) into the cold milk container and the cup containing the espresso under the milk frother (24).

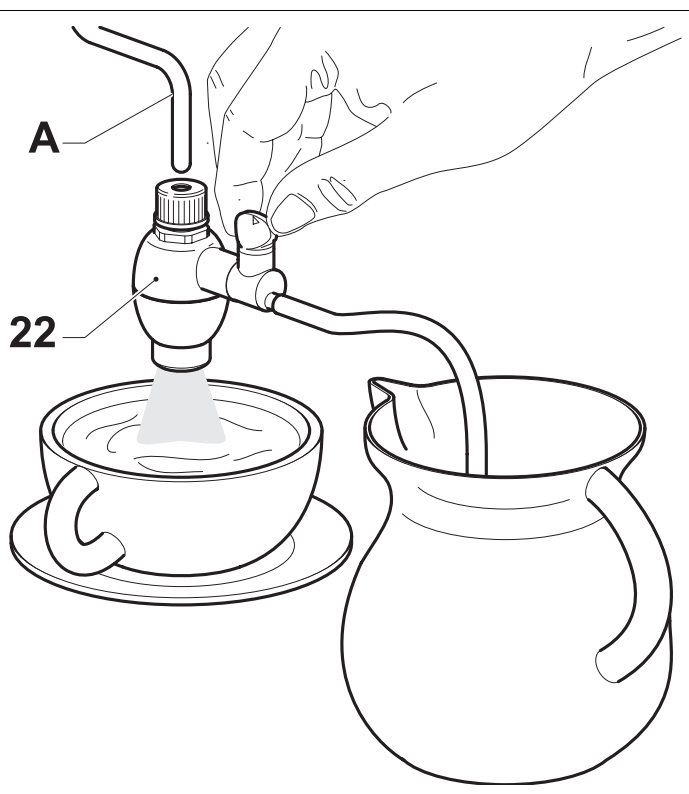
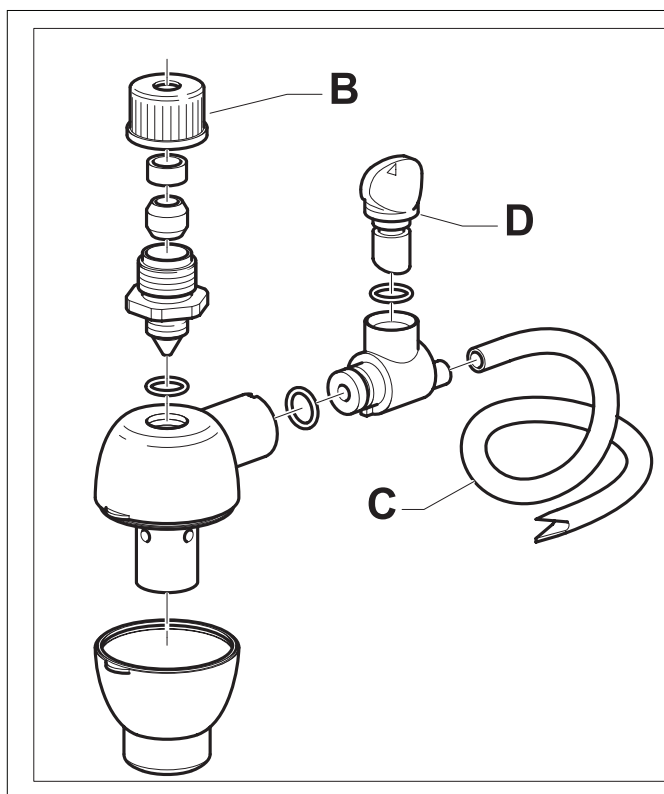

- 4 Slowly turn steam valve knob (7) counter clockwise to release steam.

IMPORTANT: *The more you turn the knob, the greater the steam pressure for frothing.*

- 5 When you have made enough froth, turn steam knob clockwise to shut off steam. Put steam switch (4) to "0" position.
- 6 Top each cup of cappuccino with a dash of cinnamon, cocoa, nutmeg. Serve.

- 7 **NOTE:** If you want to make more espresso immediately after steaming milk, the machine boiler must be refilled with water and temperature brought down to a brewing temperature.

Otherwise, espresso may taste "burned". To do this: place an empty cup on the drip plate.

Do not insert filter holder.

Turn hot water/brew switch (2) to "1" letting cup fill with water.

Turn brew switch "0".

You may now proceed to make more espresso.

- 7 **NOTE:** *If you want to make espresso immediately after making hot water, the temperature of the machine boiler must be brought down to a brewing temperature. Otherwise, espresso may taste "burned".*

To do this: place an empty cup on drip plate. Do not insert filter holder. Put the hot water/brew switches (2) and the steam switch (4) to "1", letting cup fill with water. Turn brew switch "0".

You may now proceed to make espresso.

Keeping it clean:

- 1 **IMPORTANT:** *the steam nozzle should be cleaned after each use in order to avoid build up of milk deposits that are very difficult to clean. Cleaning is made easy as can be seen in the DESCRIPTION OF PARTS. The outer part of nozzle can be removed by pulling downward.*

The outside of the steam pipe can be cleaned with a damp cloth.

The steam jet is cleaned by running a shot of steam through it.

The hole in the steam nozzle must be kept open. A needle may be used.

- 2 Clean filter holder and filter in warm water after use.

Making hot water:

1. Follow the procedure described under "Preparation".
2. Turn the power switch (1) to "1".
3. Allow about 6 minutes for the machine to reach its proper operating temperature.
4. Place a pitcher under the steam nozzle (8).
- 5 Slowly turn the steam knob (7) anticlockwise so that the hot water and put the hot water/brew switches (2) and the steam switch (4) to "1" can be released.

N.B.: *Dispensing should not exceed 60 seconds.*

- 6 Once the desired quantity of hot water is obtained, turn the steam knob clockwise and put the hot water/brew switches (2) and the steam switch (4) to "0" to stop the water release.

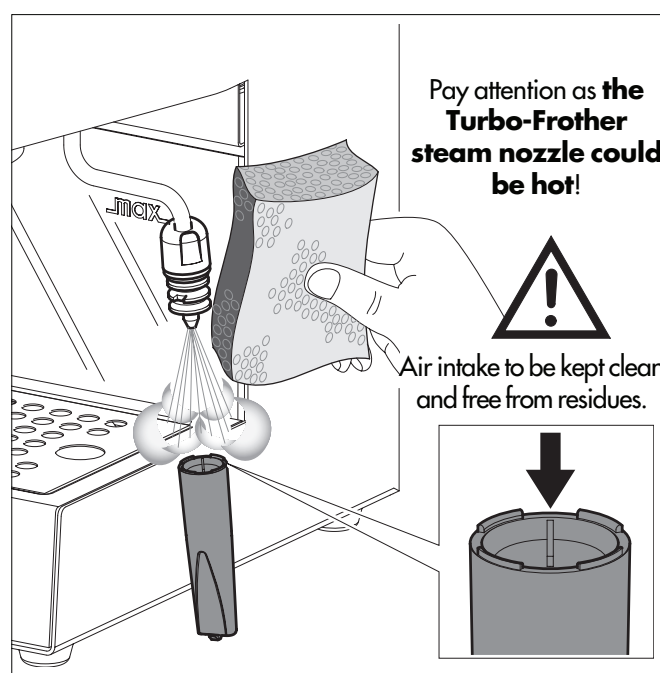

- 3 Wipe body of machine with a damp cloth as required.
- 4 Remove drip tray and plate (5-12) and wash in warm soapy water. Do not use abrasive substances.
- 5 Clean the seal (15) inside of the brewing head (14) and keep it clean.
- 6 The shower disc (17) should be unscrewed and cleaned periodically depending on frequency of use.
- 7 After long periods of non-use, drain stale water from machine by turning hot water/coffee switch to "1". However, do this only after you have filled tank with fresh water. Never operate pump unless there is water in tank.
- 8 **NOTE:** *It is very normal for an espresso machine to emit steam and drip occasionally as the water pressure changes during use.*
Be certain to empty drip tray (12) as required,

Descaling:

In hard water areas, minerals found in the water will accumulate and affect operation of the unit. Approximately every two months (this can vary depending on use and water condition), clean the machine with Gaggia descaler (in which case follow the instructions on the packet).

Remove shower disc (17) and clean.

Pour solution into tank and turn on pump for 15 seconds. Allow solution to flow through brewing head and steam nozzle for several seconds. Wait 20 minutes, then repeat. process until solution has been run through.

Rinse machine thoroughly by running plain cold water through machine. Replace shower disc (17).

NOTE: *Product failure due to scale accumulation is not covered by warranty. No other servicing should be attempted by the user. Use "Gaggia cleaner" for best results.*

In the event of faulty function

Problem:	Check to ensure against the following:
Coffee does not flow.	<i>Water is in tank. Filter basket clogged because coffee is too fine or compressed too firmly. Shower disc requires cleaning.</i>
Coffee flows too quickly.	<i>Coffee is ground too coarsely. Coffee is not pressed down with tamper.</i>
Pump makes loud noise.	<i>No water in tank. Pump not primed. Coffee is ground too coarsely.</i>
Water leaking excessively from filter holder.	<i>Filter holder not properly inserted in brew head. Gasket in brewing head dirty or worn. Coffee grinds not cleaned off the rim of filter holder.</i>
Espresso has little creamy froth.	<i>Coffee is ground too coarsely. Coffee is not pressed down with tamper. Coffee is too old or dried out.</i>
Espresso is too cold.	<i>Machine is not warmed up (6 min). Coffee is ground too coarsely.</i>
Not enough milk froth.	<i>Steam nozzle and/or air intake hole clogged. Milk is too hot.</i>